

CATEGORY : SPRING HANGERS



SERIES SHE1

DESCRIPTION

- Our spring hangers are fabricated using heavy duty steel.
- Springs are made from high quality and heavy spring steel.
- Springs are powder coated with color code for easy identification.
- Special rubber washers are provided for uniform distribution of load.

APPLICATION

Used for wide range of HVAC equipments such as fan oil units, air handling units, fans, pumps and chillers etc.

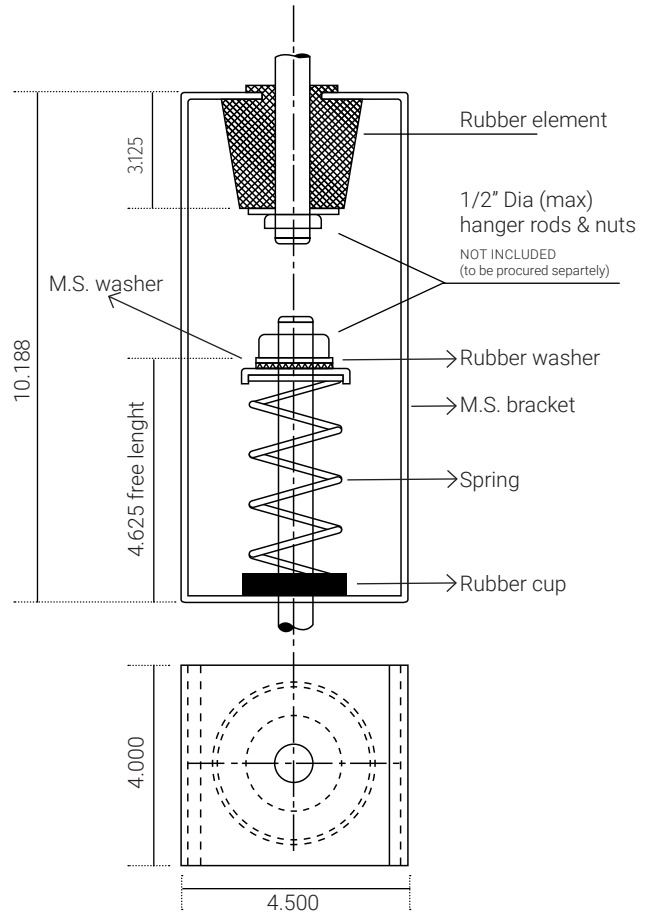

model no.	rated load (lbs)	rated load (kgs)	deflection (in)	color code of spring
SHE1 40	40	18	1.00	pink
SHE1 65	65	30	1.00	orange
SHE1 75	75	34	1.00	black
SHE1 110	110	50	1.00	blue
SHE1 150	150	68	1.00	brown
SHE1 175	175	80	1.50	green
SHE1 215	215	98	1.00	white
SHE1 245	245	111	1.00	purple
SHE1 300	300	136	1.00	yellow
SHE1 400	400	181	1.00	red
SHE1 465	465	210	1.50	d. brown

NOTE : Research and development is a continuous process with us as improvements are made from time to time, specifications/ dimensions may change without notice. Tolerances in dimensions are as per international standards.