

CATEGORY : HOUSING SPING MOUNTS



## SERIES G1

### DESCRIPTION

- Our housing spring mounts are made of high quality steel casting.
- Spring are made from high quality and heavy spring steel.
- The castings are powder coated with proper treatment for rust prevention.
- Springs too are powder coated for rust prevention and also color coded for easy identification.
- Anti skid rubber is provided at the bottom of housing for grip.
- Rubber lining inside to prevent metal to metal contact and smooth functioning.

### APPLICATION

Used for wide range of HVAC equipments such as compressors, air handling units, fans, pumps and chillers, etc.

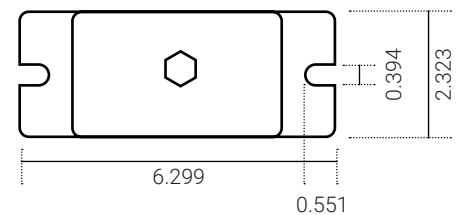
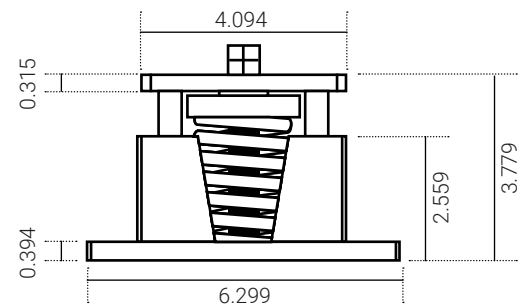
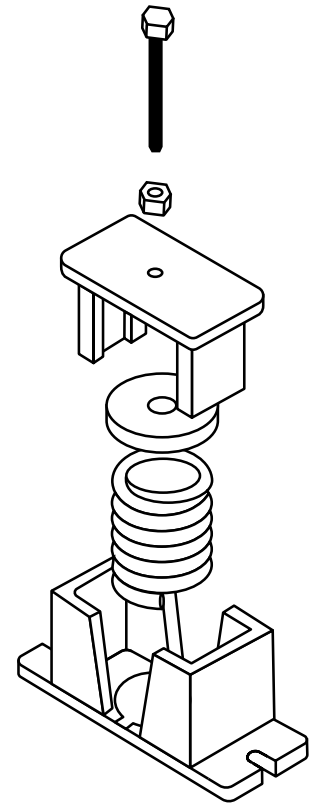

model no.	rated load (lbs)	rated load (kgs)	deflection (in)	color code of spring
G1 40	40	18	1.25	pink
G1 65	65	30	1.25	red
G1 110	110	50	1.20	blue
G1 175	175	80	1.00	brown
G1 245	245	110	0.80	white
G1 330	330	150	0.50	yellow
G1 465	465	210	0.50	black
G1 600	600	300	0.50	green

**NOTE :** Research and development is a continuous process with us as improvements are made from time to time, specifications/ dimensions may change without notice. Tolerances in dimensions are as per international standards.