

VIBS 3-7

VIBS-3-7 SERIES -MAXIMUM LOAD RANGE IN KGS.

DESCRIPTION

*Seismic rubber vibration isolator

Installation of equipments on VIB DAMPERS is the modern method of installing equipment which must be protected from shock and vibrations which are inherent in many environments. In mobile applications the equipments remains steady and isolated from the base vibrations during transit.

APPLICATION

- Diesel generating sets mounts
- Air compressors mounts (bath reciprocating type and screw compressors)
- Fan mounts and motor unit mounts
- Centrifuges mounts
- Air conditioning unit mounts
- Combustion engine mounts

NOTES

Research & development is a continuous process with us. As improvements are made from time to time. Specifications and dimensions may change without notice. Tolerances in dimensions are as per international standards.

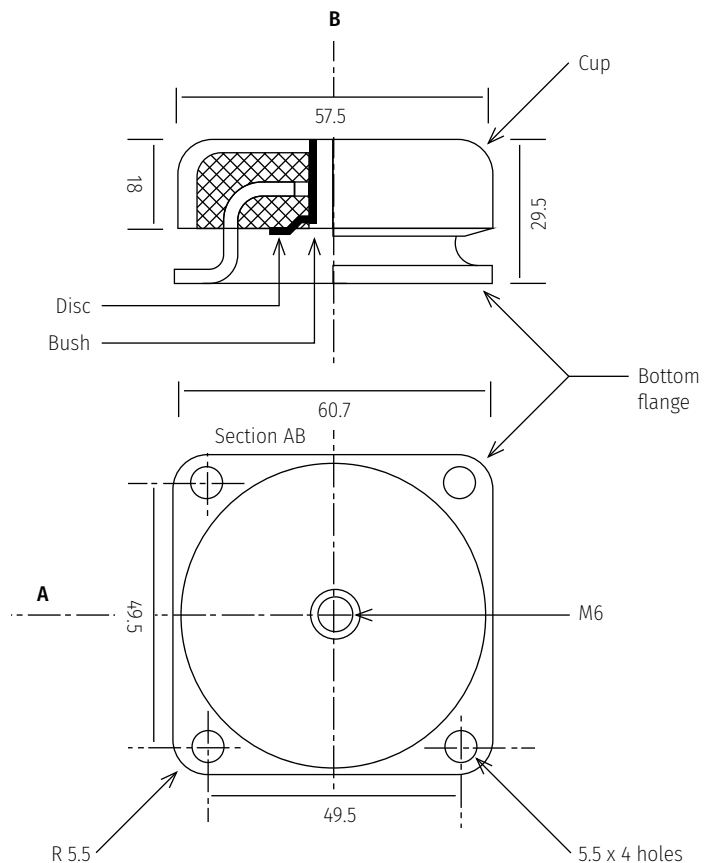

Type number	Mobile application	Static application
VIBS-3	3Kg - 5Kg	10Kg
VIBS-4	5Kg - 10Kg	20Kg
VIBS-5	10Kg - 15Kg	30Kg
VIBS-6	15Kg - 20Kg	40Kg
VIBS-7	20Kg - 25Kg	50Kg