

CATEGORY : SPRING HANGERS



SERIES SH

DESCRIPTION

- Our spring hangers are fabricated using heavy duty steel.
- Springs are made from high quality and heavy spring steel.
- Springs are powder coated with color code for easy identification.
- Special rubber washers are provided for uniform distribution of load.

APPLICATION

Used for wide range of HVAC equipments such as fan oil units, air handling units, fans, pumps and chillers etc.

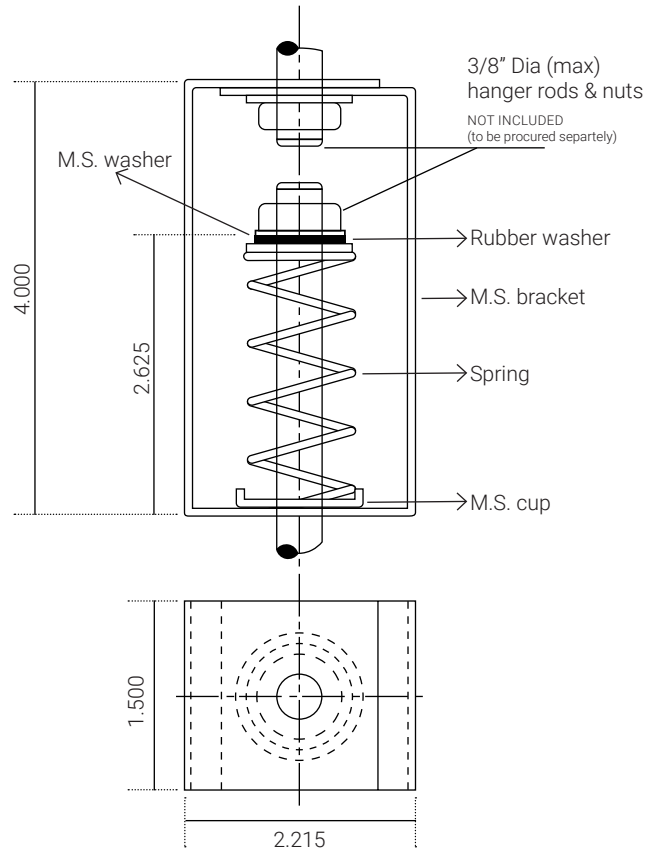

model no.	rated load (lbs)	rated load (kgs)	deflection (in)	color code of spring
SH 20	20	9	0.75	pink
SH 45	45	20	0.75	black
SH 70	70	32	0.75	red
SH 110	110	50	0.75	blue
SH 175	175	80	1.00	brown

NOTE : Research and development is a continuous process with us as improvements are made from time to time, specifications/ dimensions may change without notice. Tolerances in dimensions are as per international standards.